

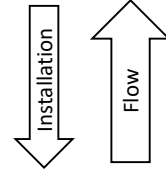

DATA SHEET REVERSE FLOW CHECK VALVE FR080-014

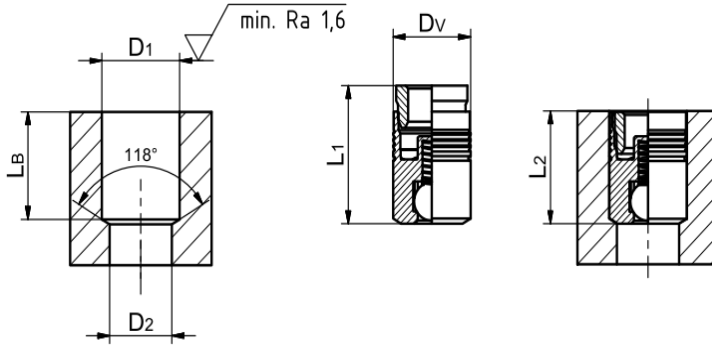

Dimensions



Bore Hole

		mm
D1	Hole Diameter Down Stream	8.15+/-0.05
D2	Hole Diameter Up Stream	6.6
LB	Min. Hole Length Downstream	10.6

Valve

		mm
DV	Valve Diam.	7.97+/-0.02
L1	Length Pin pre-assembled	12.8
L2	Length installed	10.62+/-0.05

Installation

- 1 Drill bore hole acc. dimensional drawing above
- 2 Set Flex Check valve into bore hole.
- 3 Push in pin by the indicated distance (L-push-In) with installation tool and table press.

Max. Installation Force	L-push-in (mm)
<15 KN	2.25



ΔP vs Flow

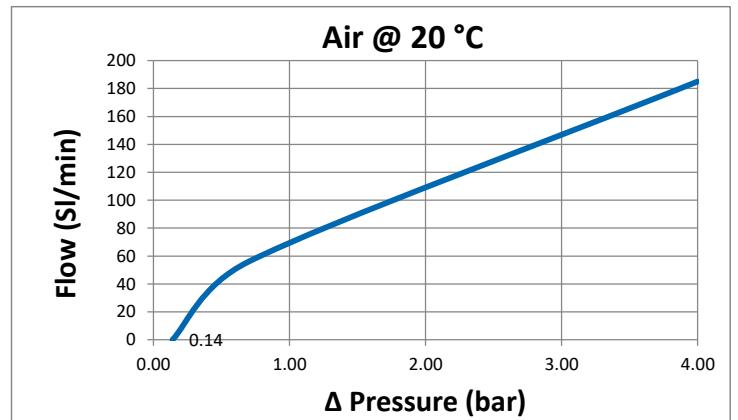
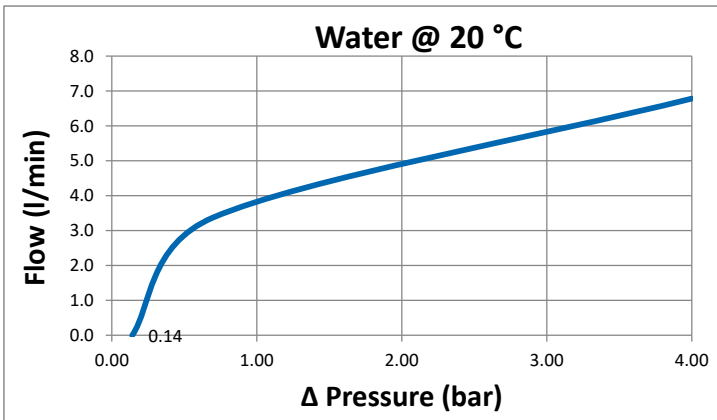

Model Code

	①	②	③	④	⑤	⑥	⑦
Product	F	R	nnn	-	nnn	/P	
Direction	Flex Check®	Reverse	Diameter (1/10 mm)	Standard	Cracking Pressure [1/100 bar]	High accuracy CP +/- 10%	
		Forward		Zero Leak		Reduced Inst. Force	
Size						Ceramic ball	
Seat						Restrictor orifice (Diam. 1/10 mm)	
						Screen 125 mcr	
CP						MedTech steel (1.4404)	
Options						Special Design	

F R 055 Z 014 /P/M... SPEZ

Performance

Cracking Pressure	0.14 bar +/-30%
Leakage	<20 sccm/min
Max. Pressure - chck/flow	400/40 bar
Max. Installation Force	<15 KN
Min. Fixation Loading	6.34710743801653 KN
Life Time Cycles	15 mio mio
Weight	4.3 g

Materials

Body	Stainless Steel
Ball	Stainless Steel
Spring	Stainless Steel

