

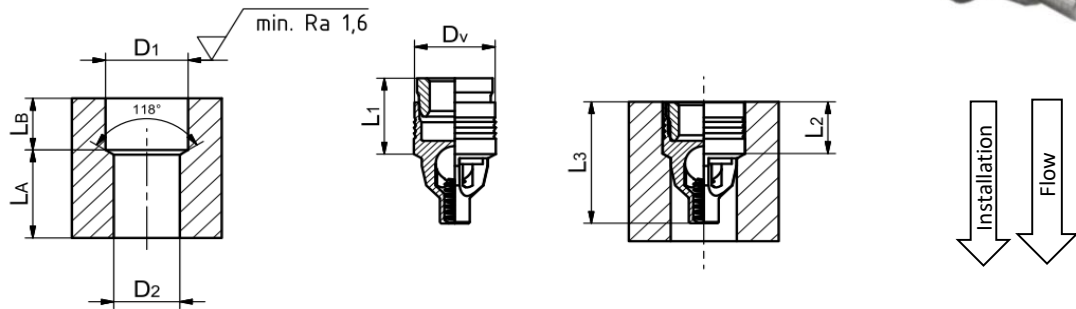

DATA SHEET FORWARD FLOW CHECK VALVE FF080-014



Dimensions



Bore Hole		mm
D1	Hole Diameter Down Stream	8.15+/-0.05
D2	Hole Diameter Up Stream	6.6
LB	Min. Hole Length Downstream	5.7
La	Min. Hole Length Downstream	7.0

Valve		mm
Dv	Valve Diam.	7.97+/-0.02
L1	Length Pin pre-assembled	7.9
L2	Length installed	5.67+/-0.05
L3	Length installed total	12.7

Installation

- 1 Drill bore hole acc. dimensional drawing above
- 2 Set Flex Check valve into bore hole.
- 3 Push in pin by the indicated distance (L-push-in) with installation tool and table press.

Max. Installation Force	L-push-in (mm)
<15 KN	2.25



ΔP vs Flow

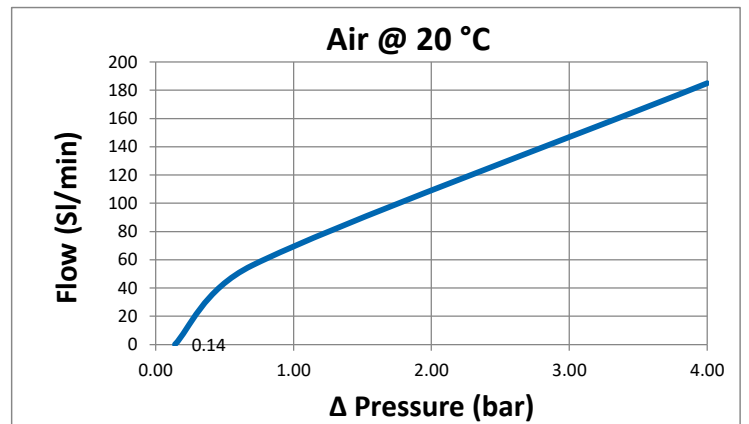
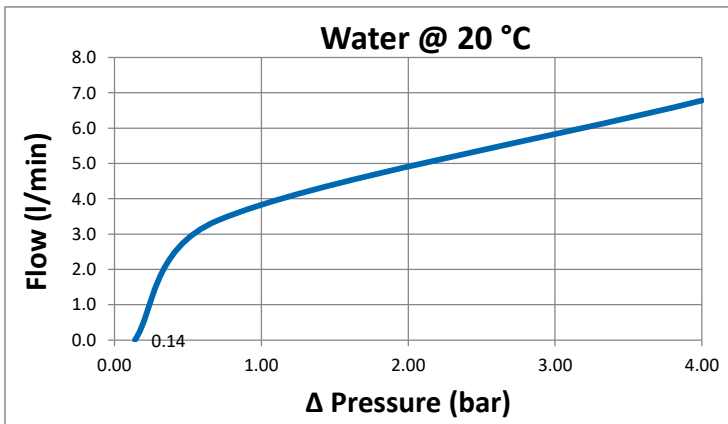

Model Code

Code	Description	Value
① Product	F	Flex Check®
② Direction	R	Reverse
	F	Forward
③ Size	nnn	Diameter (1/10 mm)
④ Seat	-	Standard
	Z	Zero Leak
⑤ CP	nnn	Cracking Pressure [1/100 bar]
⑥ Options	/P	High accuracy CP +/- 10%
	/L	Reduced Inst. Force
	/C	Ceramic ball
	/Rxyz	Restrictor orifice (Diam. 1/10 mm)
	/S125	Screen 125 mcr
	/M	MedTech steel (1.4404)
⑦	SPEZ	Special Design

Performance

Cracking Pressure	0.14 bar +/-30%
Leakage	<20 sccm/min
Max. Pressure - chck/flow	400/40 bar
Max. Installation Force	<15 KN
Min. Fixation Loading	6.34710743801653 KN
Life Time Cycles	15 mio mio
Weight	4.3 g

Materials

Body	Stainless Steel
Ball	Stainless Steel
Spring	Stainless Steel



SWISS MADE